

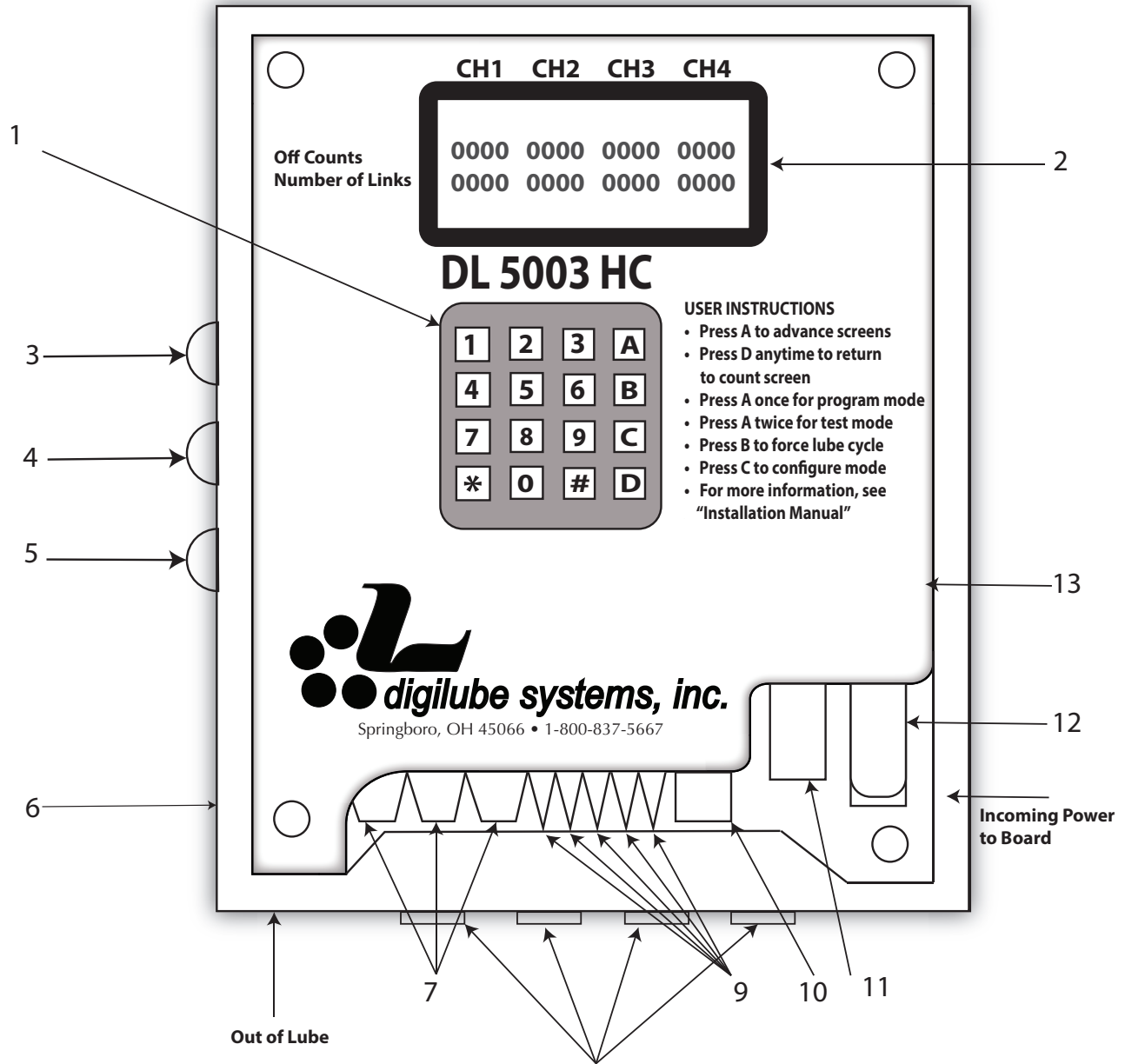

Manual Contents **DL-5003 Head Controller**

DL-5003 Controller.....	2
DL-5003 Wiring Diagram.....	3
The Digilube Programmable Lubrication System.....	4
Specifications.....	4
Sequence of Operations.....	5/6
Indicator Lamps.....	7
Installation.....	7
Mounting of the Lubricators.....	8
Power Connections.....	8
DL-5003 Definitions.....	9/10
Maintaining the Lubrication System.....	11
Programming Modes for the DL-5003HC.....	11
Link Mode.....	12
Time Mode.....	12/13
Configure Mode.....	13
Test Mode.....	13/14
Quick Test Mode.....	14
Force Lube Cycle.....	14
Limited Warranty.....	15

DL-5003 CONTROLLER



ITEM #	QUANTITY	DESCRIPTION
1	1	Keyboard
2	1	LED Display
3	1	24VDC LED Lamp Green - Clear Cover
4	1	24VDC Clear Lamp - Amber Cover
5	1	24VDC Clear Lamp - Red Cover
6	1	8X10 Fully Hinged Box
7	4	Sensors
8	4	Power In & Out
9	5	Valves
10	1	Lube Pump
11	1	GND/28VDC
12	1	DL5003 Circuit Board
13	1	Face Plate

DL-5003 WIRING DIAGRAM

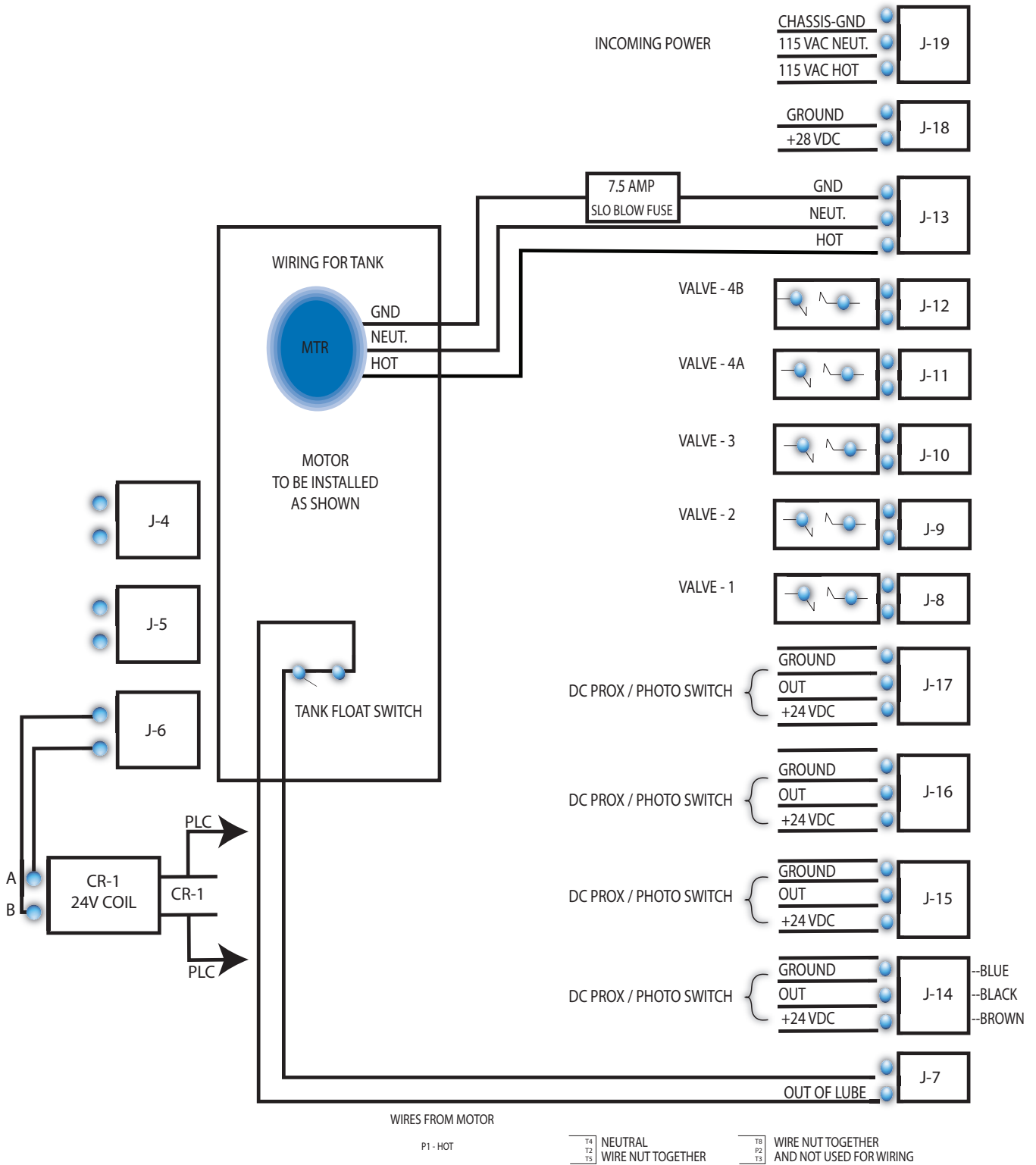

1.0 THE DIGILUBE PROGRAMMABLE LUBRICATION SYSTEM

The Digilube Programmable Lubrication System is designed for lubricating a wide variety of conveyors and machines. The DL-5003 Head Controller (HC) which controls the lubricator, is the most advanced, yet easy to use microprocessor in the industry. A large two line LCD screen and 16 button key pad provide on-screen instructions for programming the unit and adjusting the lubricator for your particular conveyor. This manual provides complete information needed to install, program, service and order replacement components for your system.

The DL series of Digilube's programmable lubricators provide pinpoint accuracy of lubricant to many different types of conveyors' lube points. Typical areas of lubrication include:

- Chain pins
- Open trolley bearings
- Free carriers
- Swivels
- Cat drive chains
- Roller chains

Each system has a lubricator which consists of a DL-5003HC, valve(s) sensor(s) and a lubricant tank. The DL-5003HC is a Programmable Microprocessor Head Controller that controls the system. Each HC includes:

- Four (4) independent channels
- 24 VDC outputs
- Four digit PIN security code
- Easy-to-read LCD screen
- 16 button key pad

2.0 SPECIFICATIONS

LUBRICATOR WITH DL-5003HC

Dimensions/Weight	Lubricator will vary depending on type of conveyor and/or if pre-mounted to conveyor rail
DL-5003HC (Head Controller)	15lbs - 8" x 10"
Circuitry	Solid state electronics, microprocessor controlled
Power Requirements	115 VAC 10 Amps or 24 VDC 10 Amps
Operating Temperatures	45° F minimum - 120° F maximum
Relative Humidity	5-90% Non-Condensing
Authorization Security Code	Four (4) digit, reset at factory to 0000
Memory	EPROM
Lube Time (Volume Control)	Adjustable settings from 0001 to 9999
Paint/Color	Burgundy with Gray Logo

LUBRICANT TANKS: The lubricator can be connected to three different size tanks. They are 6, 12, and 65 gallon. Each tank is designed to provide lubricant to both single and multiple conveyors.

<p style="text-align: center;">6 Gallon Tank DL-806</p>	<ul style="list-style-type: none"> • 6 Gallon • 18 1/2" H x 12 1/2"W x 15"L 60 • Can be mounted on the conveyor track in the back of the lubricator or positioned waist high on a column for easy filling. • The DL-9000 power supply comes in either 115 VAC or 24 VDC output
<p style="text-align: center;">12 Gallon Tank DL-812</p>	<ul style="list-style-type: none"> • 12 Gallon • 22 1/2" H x 12 1/2" W x 15"L WT 75# • Comes with or without DL-9000 power supply • Positioned waist high on column for easy filling • The DL-9000 power supply comes in either 115 VAC or 24 VDC output
<p style="text-align: center;">65 Gallon Tank DL-865</p>	<ul style="list-style-type: none"> • 65 Gallon • 49"H x 22 1/2"W x 22 1/2"L WT210# • Comes with or without a DL-9000 power supply • The tank is designed to provide lubricant from a single source to multiple lubricators • The DL-9000 power supply comes in either 115 VAC or 24 VDC output

POWER SUPPLIES

Power Requirements	<ul style="list-style-type: none"> • 115 VAC, 10 AMPS • Motor / Pump 115VAC, 1/3 HP, 6 AMPS, Gear • With Gear Model 42FAR, Motor must rotate clockwise with above pump
Pressure Gage/ Filter	120 - 160 psi, liquid filled, in-line
Lubricant Level	<ul style="list-style-type: none"> • Electronic sensor with red indicator on all tanks • Clear top mounted barrel gage on all tanks
Paint/Color	Gray with Burgundy Logo
Lubricant Viscosity	Approx. range: 30-500 SSU at 100°F

3.0 SEQUENCE OF OPERATIONS

LUBRICANT CYCLE

When a lubrication cycle is about to begin (actually 8 sensor activation's prior to operation), the pump/motor will start and maintain lubricant pressure to the valve(s) throughout the lubrication cycle. Each time a sensor is activated, the valve will dispense lubricant onto the desired point(s). After completion of the lubrication cycle, the valve(s) will deactivate to normally closed. The pump/motor will continue to run for approximately five (5) minutes and shut off.

DURING LUBRICANT CYCLE

During a lubrication cycle, if the conveyor stops, the pump/motor will run for approximately five (5) minutes then shut off. Once the conveyor restarts and the channels sensor activates, the pump/motor will restart, thus completing the lubrication cycle.

LUBRICANT LEVEL

If the Lubricant Tank's lubricant level runs low, the pump/motor will also shut off and the red indicator lamp will turn on at the DL-5003HC. The DL-5003HC will turn off sensors and valves, and a screen will also indicate the following flashing message: OUT OF LUBRICANT. Once the tank is refilled with lubricant, the lamp will turn off, the pump/motor will turn on and the DL-5003HC will resume lubricating where it left off in the ON CYCLE mode. Note: If intermittent power loss occurs, the DL-5003HC will retain its memory count in the program.

THIN FILM LUBRICANTS

All Digilube Lubrication systems are designed to use only thin film lubricants. A pressure setting between 30-80 PSI, depending on the length and elevation of supply tubing from the tank to the lubricator(s) and the number of solenoid valve(s) in the system.

OFF CYCLES (NON-LUBRICATION MODE)

When all channels in the system are in the OFF CYCLES (NON-LUBRICATION MODE) the pump/motor is off. The lubricant pressure in the supply tubing is maintained at the High Pressure Level Regulator setting of 30-80 PSI by a check valve at the lubricant tank. The solenoid valve(s) will not be operating although the LED sensor(s) will be counting each detection.

LUBRICATION CYCLE

When a channel's OFF CYCLES reaches 0000, it goes into a lubrication cycle. As the valve(s) open and close, the lubricant pressure in the supply tubing begins to drop. Once it reaches the Low Pressure Level Switch setting the pump/motor turns on. The pump/motor will continue to run until the High Pressure Level Regulator setting has been maintained for 5-10 minutes. Once this occurs, the pump/motor will turn off, indicating that the solenoid valve(s) have been closed for that period of time.

PUMP/MOTOR

The pump/motor will also turn off if the lubricant tank runs low of lubricant and a red indicator lamp on the DL-9000PS turns on. Filling the tank will automatically restart the pump/motor and turn off the red lamp.

PUMP/MOTOR SHUT DOWN

The pump/motor will shut down if one of the three situations are present:

- The channel(s) on the DL-5003HC have completed their lubricant cycle(s)
- Conveyor has stopped for more than 25 minutes
- The fluid level in the tank is low

4.0 INDICATOR LAMPS

Green Lamps

Indicates power to the DL-5003HC or DL-9000PS. This lamp will be on at all times, except during power loss.

Yellow Lamps

Indicates the pump/motor is running and a request for lubricant from a lubricator has occurred.

Red Lamps

Indicates the lubricant tank is low of lubricant. The red lamp also indicates the pump/motor have automatically shut down to prevent air from getting into the supply tubing. The red lamp will automatically turn off and the pump/motor will restart when the lubricant tank is refilled. **NOTE: The red lamp on the DL-5003HC does not operate when used with a DL-9000PS. The red lamp on the DL-9000PS will operate along with the green and yellow lamps. Optional rotating tower indicators are also available.**

5.0 INSTALLATION

SITE SELECTION

The best location for a lubricator on a conveyor with a washer/oven is on a straight level section of rail between the load and unload area where there are no parts present. However, many times the load & unload area is in the same place where people are also working. The next best location would be after the raw parts are loaded before the washer. If lubricant does drip on a part it is washed off prior to painting. If the installation is before the washer, a minimum of 5-7 minutes travel time if chain goes through washer. It is very important that the conveyor chain be properly protected in the washer. Mount at a point on the conveyor that ensures chain stability and that the chain is under tension. Vibration should be minimal and bearings should be rolling as they pass the lubricator. Avoid unstable or hazardous environments like high temperatures, water or chemical exposure.

We recommend that the DL-806 & DL-812 Lubricant Tanks be located on a structural column waist high for ease of filling. When using a 65 gallon tank with multiple lubricators, centralize the tank within the circumference of the lubricators and out of high traffic fork truck areas.

6.0 MOUNTING THE LUBRICATORS

An Enclosed Track Lubricator comes mounted on a 28" track rack and a Monorail I-Beam Lubricator comes pre-mounted on a 24" track section of an I-Beam for ease of installation. The lubricator can also be installed on the customers' existing conveyor and is usually done by a contractor or a Digilube Systems Service Representative.

MOUNTING DL-806 & DL-812 LUBRICANT TANKS

DL-806 & DL-812 LUBRICANT TANKS

The DL-806 can be installed at a remote location for ease of filling or on conveyor rail right behind the lubricator. If the tank is mounted with the lubricator, weld the pre-mounted track section in place and connect to 115VAC, 10 AMP continuous power source. Due to it's size, the DL-812 lubricant tank should not be mounted on the rail.

STEPS FOR REMOTE INSTALLATION:

1. All lubricant tanks w/o DL-9000PS require that the power source (115vac) be run from the lubricator back to the lubricant tank.
2. When installing nylon tubing, push the tubing firmly and as far as possible into the quick-connect fitting located next to the motor on the tank.
3. Make sure the proper connection is made by pulling back on the tubing. This will lock-in the tubing. The supply tubing is fastened to the electrical conduit connecting the tank to the lubricator with wire ties. The tubing can also be connected to overhead building structural members with wire ties or beam clamps. Sharp bends in the supply tubing will slow or stop lubricant flow and must be avoided.
4. To remove the tubing, push in on the fitting collar while pulling out on the tubing. The self-locking fitting is reusable. The nylon tubing is usually 1/4" O.D. However, steel or copper tubing should be used for high-temperature service, which will require different fittings.
5. If there is power to the DL-5003HC the red lamp will be on. Once the tank is filled with lubricant the red lamp will turn off.

7.0 POWER CONNECTIONS

DL-806 & DL-812 LUBRICANT TANKS - MOUNTED W/ LUBRICATOR

Connect incoming power to hot, neutral, and ground to J19 on the DL-5003HC's terminal strip.

DL-806 & DL-812 LUBRICANT TANKS - FROM A REMOTE LOCATION

1. If the tank is installed at a remote location, run five (5) 16 gauge wires (1 black, 1 white, 1 green, 2 red) from the DL-5003HC to the motor and float.
2. At the DL-5003HC's terminal strip, the black and white wires connect to J13 and the two red wires connect to J7.
3. At the Tank, connect the two red wires to the two yellow float switch wires.
4. Connect the black and white wires to the motor leads for low voltage - 115 VAC.
5. Connect incoming power to hot, neutral, and ground to J19 on the DL-5003HC's terminal strip.

8.0 DL-5003HC DEFINITIONS

The Digilube system is controlled by the DL-5003HC. This microprocessor-based circuitry has four (4) independent channels which provide the user with the ability to insert the desired lubrication settings and to change settings whenever required while in the field. The DL-5003HC will automatically read these settings and incorporate them into its performance.

Link Mode	The <i>Link mode</i> is one option to program the DL-5003. It is used with a detection sensor. The sensor reads objects which pass in front of it like trolley wheels, chain pin links, rollers, etc. In a lubrication cycle, the sensor, when activated, will open up a solenoid valve and dispense lubricant. In both lubrication and non-lubrication modes, the sensor will count the number of objects which will then be processed by the DL-5003HC. Once programmed, the DL-5003HC will input these detections and lubricate accordingly.
Time Mode	The <i>Time mode</i> is another option to program the DL-5003. This mode is used without any sensors. It functions on TIME only. The user determines when and how much lubricant will be dispensed at a given lube point. This mode is used on high speed chains, stationary lube points like sprockets and on machines.
Off Cycle	In the <i>Link mode</i> , the OFF CYCLE means the number of completed cycles of the conveyor in a non-lubrication mode. EXAMPLE: A conveyor 300 feet long, traveling 600 feet during a non-lubrication mode has completed TWO OFF CYCLE.
# of Links / # of on Counts	The " <i># of Links</i> " (<i>Link mode</i>) # of ON COUNTS (<i>TIME mode</i>) means the total number of trolley wheels, center links, rollers, etc that make up a complete cycle of the conveyor. This is also the number of valve activations which will occur in the during a lube cycle of the program. When a lube cycle begins, the OFF COUNT is at zero (0000). In the <i>Time mode</i> , this also corresponds to the number of shots of lubricant in the lube cycle.
To Determine "On Count" for forged link x-chain	Take the number of center links that the detection sensor will detect in a one foot section and multiply it by the conveyors' length in feet. (# of center links X conveyors length in feet)

EXAMPLE (1): A conveyor 500 feet long having an X348(3") pitch chain will activate the detection sensor 2.0 times per foot of chain length. Therefore $2 \times 500 = 1000$ "ON COUNTS."

EXAMPLE (2): A conveyor 500 feet long having an X458(4") pitch chain will activate the detection sensor 1.5 times per foot of chain length. Therefore $1.5 \times 500 = 0750$ "ON COUNTS".

EXAMPLE (3): A conveyor 500 feet long having an X678(6") pitch chain will activate the detection sensor 1.0 times per foot of chain length. Therefore $1.0 \times 500 = 0500$ "ON COUNTS".

EXAMPLE (4): An enclosed track conveyor with 6" pitch chain will activate the detection sensor 2.0 times per foot of chain length. Therefore $2.0 \times 500 = 1000$ "ON COUNTS".

EXAMPLE (5): An enclosed track conveyor with 8" pitch chain will activate the detection sensor 1.5 times per foot of chain length. Therefore $1.5 \times 500 = 0750$ "ON COUNTS".

Pin Security Code

In order to program the DL-5003HC, it is necessary to know the four-digit PIN security code. This will enable the user to restrict the number of people authorized to maintain the equipment and to change program settings. The code is preset at the factory at 0000. See 15.0 on Configure mode for instructions on setting a different security code.

Delay Time

Delay time can be set between 0001 and 9999. This indicates the amount of time the DL-5003HC will not accept another input from the detection sensor, thus preventing multiple shots of lubricant at the points to be lubricated. Generally a setting of 0500 or .5 sec will be sufficient however, when sensing an irregular casting or multiple wheels (such as a free trolley carrier) this setting will need to be increased to cover the entire field of the object.

Configure Mode

This mode allows the user to change the four digit PIN security code. This number keeps unwanted changes to the programmed settings. This mode also allows user to change the real-time clock for the TIME mode portion of the DL-5003HC. This allows for time zone differences and time drift over a period of years. This mode can also change the baud rates (ASCII COMMUNICATION) if an optional modem is used. Press C to enter configuration mode and follow on screen instructions.

Test Mode

This mode enables the users to override the programming of the DL-5003HC. Each channel can be enabled or disabled, to manually open and or close a solenoid valve or to put into a continuous lube cycle for routine preventive maintenance requirements. See 16.0 for detailed operation.

Force Lube Cycle

This cycle zero's the OFF COUNTS. This will force a lube cycle on the next sensor detection. After the lube cycle has been completed, the channel will automatically return to its programmed OFF CYCLES. See 18.0 for detailed operation.

Valve Time Setting

This determines the amount of time the solenoid valve(s) will be open. The longer the valve is open the more lubricant will be dispensed. A setting of 0000 is off. A 0001 is required for the valve to function properly and will dispense the least amount of lubricant and a 9999 will dispense the largest amount.

EXAMPLE SETTINGS: Please keep in mind every conveyor and application is different. The settings listed below are good starting points - check your chain and trolleys frequently making changes as needed. On Enclosed Tracks (Unibilt/Rapid) the vertical load wheels

UNIBILT/RAPID	VERTICAL WHEELS 0001	GUIDE ROLLER/PIVOT PTS 0001
X348	CHAIN PINS 0008	TROLLEYS 0010
X458	CHAIN PINS 0008	TROLLEYS 0010
X678	CHAIN PINS 0010	TROLLEYS 0014

9.0 MAINTAINING THE LUBRICATION SYSTEM

The Digilube Lubrication System with the DL-5003HC is one of the most advanced lubricator on the market today. It will provide many years of trouble free lubrication. However, regular maintenance is a must to insure the equipment is operating properly, dispensing tubes properly adjusted and that the conveyor is getting the correct amount of lubricant. The plant maintenance personnel should inspect the system at least monthly if not weekly.

The following maintenance steps should be adhered to closely:

1. Check lubricator to make sure dispensing tubes are properly adjusted. Make sure all dispensing tube outlets for each valve are at the same level to prevent dripping from lower tubes.
2. Inspect the sensor(s) LED for proper activation and make sure the sensor is tightly secured onto the bracket.
3. Inspect conveyor chain, trolleys, etc for sufficient amount of lubricant
4. Check and maintain a sufficient amount of lubricant in the tank to prevent automatic shutdown caused by an empty tank.
5. If the maintenance department does not have the personnel to devote to maintaining the equipment, a Preventative Maintenance Service Contract by Digilube Systems or an authorized representative is recommended.

10.0 PROGRAMMING MODES FOR THE DL-5003HC

Programming the DL-5003HC is very easy if a few things are kept in mind.

Press A once	Program Mode
Press A twice	Test Mode
Press B	Force Lube Cycle
Press C	Configure Mode

While programming a channel, remember the following:

1. **Press A** to advance screens
2. **Press D** anytime to return to Main Screen
3. Follow the Screen Prompts
4. When changing values, press * button to save the new values

CHANNEL ASSIGNMENT(S)

Monorail I-Beam Lubricator		Enclosed Track Lubricator	
CH1	Chain Pins	CH1	Vertical Wheels
CH2	Open Trolley Wheels	CH2	Pins & Horizontal Wheels
CH3	Cat Drive Chain / Swivel	CH3	Cat Drive
CH4	Free Carrier	CH4	Free Carrier

10.1 LINK MODE

The *Link Mode* is one of two ways to program the DL-5003HC. It is typically used on most applications that require a sensor to detect moving lube points. ie: x-chain pins, trolleys, vertical wheels, pivot points, guide rollers, horizontal rollers, slides, etc.

MAIN COUNT SCREEN	CH1	CH2	CH3	CH4
OFF COUNTS	0000	0000	0000	0000
# OF LINKS	0000	0000	0000	0000

1. From the four channel main screen, **press A**
2. **Press *** to enter *Program Mode*
3. Enter pin # 0000 = factory default (to change pin #, see configure mode)
4. Correct pin #, **press *** to continue
5. Select channel to program (1 to 4), **press A** to continue
6. Ch1 operation mode, link mode, **press A** to continue
7. Ch1 select # of off cycles, **press *** to save, **press A** to continue
8. Ch1 select # of links, **press *** to save, **press A** to continue
9. Ch1 select valve setting, **press *** to save, **press A** to continue
10. Ch1 select delay (if applicable), **press *** to save, **press A** to continue

You've just completed programming Ch1, **press A** to program the remaining channel(s), you must now choose another channel or you will scroll through previous channel's screens or press D to return to the main count screen.

By **pressing A** you return to the first programming screen.

10.2 TIME MODE

The *Time Mode* is the second way to program the DL-5003HC. It is an elapsed timer that is used to lubricate sprockets and/or high speed chains where a sensor(s) cannot be used on a wide variety of machines. In this mode, the user programs the channel for cycle time which indicates the time between lubrication cycles, on counts which indicates the number of shots of lubricant, lube time which determines how long the valve remains open, and duration between which indicates the length of time between each shot of lubricant.

MAIN COUNT SCREEN	CH1	CH2	CH3	CH4
00 DAYS 00 HOURS	0000	0000	0000	0000
00 MIN 00 SEC	0000	0000	0000	0000

The factory default is in the *Link Mode*. To change it to time mode, press A from the main screen.

1. From the four channel main screen, **press A**
2. **Press *** to enter *Program Mode*
3. Enter pin # 0000 = factory default (to change pin #, see configure mode)

4. Correct pin #, **press *** to continue
5. Press * to disable link mode
6. Press #* for *Time Mode*, **press A** to continue
7. Enter cycle time (time between lubrication cycles), **press *** to save, **press A** to continue
8. Enter # of on counts (amount of lubricant), **press *** to save, **press A** to continue
9. Enter valve setting (amount of lubricant), **press *** to save, **press A** to continue
10. Enter duration between (length of time between each shot), **press *** to save, **press A** to continue

You've just completed programming one channel in the *Time Mode*. Select another channel or **press D** to return to the main count screen.

10.3 CONFIGURE MODE

The Configure Mode allows user to change pin numbers, real time clock (in the time mode only) and choose different baud rates for ASCII communication (not functional at this time).

1. From the four channel main screen, **press A**
2. **Press *** to enter *Configure Mode*
3. Enter pin # 0000, press * to continue
4. **Press *** to begin new pin #
5. Enter new pin #, **press *** to save, **press A** to continue
6. Use buttons to change time as indicated on the screen, **press A** to continue
(2=up, 8=down, 4=left, 6=right)
7. Baud rate not functional, **press A** to continue
8. **Press D** to return to the four channel main screen

You have now completed changes to your pin number and/or time clock.

10.4 TEST MODE

Allows the user to:

- **Enable/Disable a Channel:** This feature is used primarily during installation and is routine maintenance checks. When adjusting the dispensing tubes for the first time, it allows the installer, to remove air from the supply line(s) and/or to adjust the dispensing tubes, one valve at a time. This reduces an accumulation of lubricant on the rail, floor, parts, etc from misdirected dispensing tubes.
- **Open/Close a Valve:** This feature is used mainly during installation/startup to bleed air out of the nylon supply tubing, or whenever air is trapped in the tubing.
- **Continuous Lube:** This feature will immediately put the channel into a continuous lube cycle. Use this mode if the conveyor chain is extremely dry, and you want to lube it several cycles or if the conveyor requires continuous lubrication.

First you must select the channel you want to program.

1. From the four channel main screen, **press A**
2. **Press *** to enter *Program Mode*
3. Enter pin # 0000 = factory default (to change pin #, see configure mode)
4. Correct pin number, **press *** to continue
5. Select channel to program (1 to 4), **press A** to continue, **press D** to exit

After selecting the channel you want to program, *Test Mode* allows the user to enable/disable any channel, open/close any valve or begin a continuous lube cycle.

1. From the four channel main screen, **press A TWICE**
2. **Press *** to enter *Test Mode*
3. Enter pin number = 0000, **press *** to continue
4. **Press *** to toggle - enable/disable selected channel, **press A** to continue
5. **Press *** to toggle - open/close a valve manually, **press A** to continue
6. **Press *** to toggle yes or no - continuous lube cycle, **press A** to continue
7. **Press D** to return to the main count screen

10.5 QUICK TEST MODE

The *Quick Test Mode* allows you to begin a lubrication cycle with a pre-determined amount of links/shots of lubricant. Once the number of links/shots is completed, the lubricator will go back to the previous off cycle settings. This mode is a great way to check the working condition of the lubricator and determine the correct position of the dispensing tubes without over lubricating the conveyor chain.

1. From the four channel main screen, **press B#**
2. Enter the number of links/shots, **press #** to start
3. After the initial programming of the links, **press #**** to check for proper lubrication

10.6 FORCE LUBE CYCLE

The *Force Lube Cycle* allows the user to begin a lube cycle immediately. This is usually done if the chain looks unusually dry and you want to lube it but keep the existing program.

- **Press B** to advance screen to Force Lube Cycle
- **Press *** to Force Lube Cycle
- Enter appropriate channel and **Press *** to start

11.0 LIMITED WARRANTY

The Digilube Lubrication System is pretested and guaranteed to be in optimum condition when it leaves our factory. The DL-5003HC is fully guaranteed against defective materials and/or workmanship for a period of thirty-six (36) months from the date of purchase.

Any portion of the DL-5003HC which fails during this period for either of the above reasons, excluding normal replacement parts such as indicator lamps, fuses, etc., will be repaired or replaced at our option, if returned prepaid to our factory. All defective parts returned for warranty service is fully inspected to determine cause of failure before warranty is approved.

All other equipment components are guaranteed against defective materials or workmanship for a period of twelve (12) months from the date of purchase. Our warranty is limited to the obligation to repair or replace our equipment only. The warranty is parts only and does not include labor. This warranty gives you specific legal rights and you may have other rights which vary from state to state.

The Digilube warranty will be void if any of the following conditions are found to exist relative to Digilube's equipment:

- Electronics components tampered with, or short circuited
- Damaged caused from voltage or environmental conditions exceeding the operating conditions:
 - » Operating Temperatures 45° F minimum- 120° F maximum
 - » Relative Humidity 5 – 90% Non Condensing
 - » Failure due to using lubricants that do not fall with the specified viscosity range.
 - » All non Digilube lubricants must be approved, in advance by Digilube Systems Inc. to maintain warranty coverage.