

Springboro, OH 45066
937-748-2209
sales@digilube.com
www.digilube.com



DL-60, 6 INCH

Parts List.....	2
Expanded View.....	3
Operation.....	4
Mounting.....	4
Air Supply.....	4
Electrical Needs.....	4
Start-up.....	5
Clock Programming.....	5
Wiring Diagram.....	6
Programming Steps.....	7
Motor Wiring Diagram.....	8
Drawing of DL-60.....	9

DL-60 PARTS LIST

ITEM #	QUANTITY	PART #	DESCRIPTION
1	2	E06397	Split Phase TEFC Motor
2	varies	G13750	1-1/8" Standard Spacers
2*	varies	G13746	1-5/8" Spacers
3	4	G13450	10" Crimped Brush
3*	4	G13490	11" Crimped Brush
4	2	G13503	13" Crimped Brush
4*	10	G13505	15" Crimped Brush
5	1	E06305	DL-60 Brush Controller
6	2	H14700	Upright Bracket
7	2	F11650	1/4" - 1/4" Prestolok Male Connector
8	2	F12559	Snubber, Air Valve
9	1	F13005	120 VAC Air Valve
10	1	F13005-1	Din Connector for Valve
11	1	G13513	Air Cylinder for DL-60
12	2	F11900	1/4" - 1/8" NPT Male Connector
13	1	G13512	Main Frame Assembly



Replacement Brush Set for 6" A02255-6RB		
QUANTITY	PART #	DESCRIPTION
4	G13450	10" Replacement Brush
4	G13490	11" Replacement Brush
2	G13503	13" Replacement Brush
10	G13505	15" Replacement Brush
10	G13750	1-1/8" Standard Spacers
4	G13746	1-5/8" Spacers

Main Frame Assembly Items	
ITEM #	DESCRIPTION
14	Shaft Coupler (3/4 Bore)
15	Coupler Spider
16	Shaft Coupler (1-1/4 Bore)
17	Flange Mounted Ball Bearing
18	Brush Arm Plate
19	Bottom Brush Arm Plate
20	3/8-16 x 3/4 SHCS includes: 3/8" Lock Washer
21	Shaft Key
22	16" Brush Shaft
23	Gear Rack
24	Air Valve Mounting Bracket
25	Spur Gear Machined (1" Bore)
26	Gear Support
27	Gib
28	Arm Bracket Frame

DL-60 EXPANDED VIEW

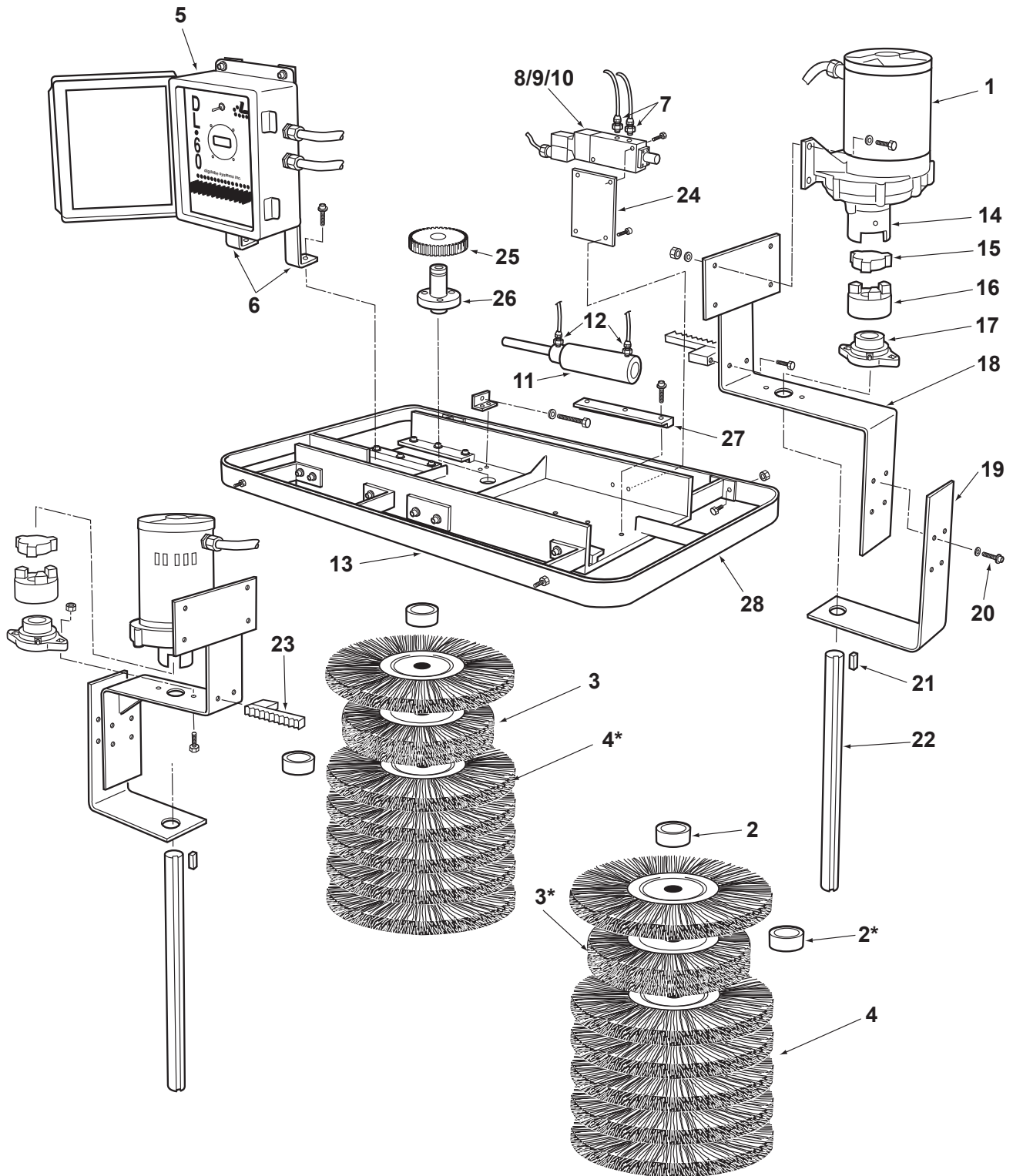

The Digilube Systems DL-60 Power Chain & Trolley Cleaning System is powered by twin direct drive gear motors to provide maximum brush torque without the use of chain, belts, sprockets or pulleys. This unit is designed to remove and prevent the buildup of paint, dirt, scale, and rust on the conveyor's chain and trolleys.

Operation

The controller on the DL-60 allows the user to program the cleaning operation for either automatic or manual modes. In either mode the controller will automatically reverse the rotation on the brushes every time the unit is started. This feature helps prolong the life of the brushes and allows the brushes to attack the buildup from a different direction for more effective cleaning. While the programmable controller will allow up to 8 (on/off) complete cleaning cycles every day when set in the automatic mode, most conveyors will reach optimum conditions when cleaned once a week. As the cleaning cycle begins, the controller provides power to each motor. Once the motors are rotating, the air cylinder will engage and bring the arms in to begin the cleaning process as the brushes make light contact with the passing conveyor chain and trolleys. The amount of brush contact is determined by the adjustable stop located on top of the base plate. Upon completion of the cleaning cycle, the brushes retract and stop rotating. When in automatic mode, the system will shut down until the next cleaning cycle. In the manual mode, the DL-60 must be turned on or off by the power switch located inside the controller.

Mounting

Before mounting the DL-60 into place, consideration should be given to the location of the unit and how the weight of the unit may affect the conveyor. The preferred locations for mounting is: (a) between the load and unload area or (b) before the washer. In some applications such as in an inverted unit, additional supports may be needed to support the DL-60. The DL-60 should be lifted into place with chains attached to the outer sides of the base plate. Once in place, the DL-60 should be centered on the rail and secured by welding the front and rear mounting tabs to the top of the rail. The dust curtain should be attached to the frame with the enclosed mounting hardware.

Air Supply

A regulated and filtered plant air supply line is required for operation. The DL-60 requires a minimum of 40psi of compressed air for operation.

The regulator and filter are to be supplied by the customer. A quick disconnect should be used to allow for easier service as needed.

Electrical Needs

The DL-60 requires 115 VAC 25 amp service. The DL-60 is completely wired and the only connection needed to be made is the incoming power. A knockout hole located in the bottom of the controller is provided for the incoming power. Please refer to the wiring diagram for actual connections.

Start-up

Before you first start up the DL-60, it is necessary to first adjust the brushes so that they are equally positioned against the chain and trolleys. To accomplish this:

- * You must first turn the plant air to the unit off and release the pressure from the cylinder by removing one of the 1/4" air lines from the solenoid valve.
- * Next remove the ring clamp on top of the ring gear.
- * Pull the gear straight up so the brush arms will move freely.
- * Adjust the stop set screw for maximum arm movement.
- * Adjust both arms so that they apply light pressure against the chain and trolleys.
- * At this point reset the ring gear and adjust the stop set screw to restrict the arms from moving in further, and reconnect the plant air line.

To program the clock of the DL-60 controller:

You should first press the reset button located in the center of the clock. This will remove any presets from the controller and avoid inadvertent operation of the unit. You should then proceed to set the actual time and day of the week into the clock. Once this has been accomplished you can now program in up to 8 complete cleaning cycles per day, however most systems can be kept clean with a single cleaning once a week or less. For complete programming, see page 7.

DL-60 WIRING DIAGRAM

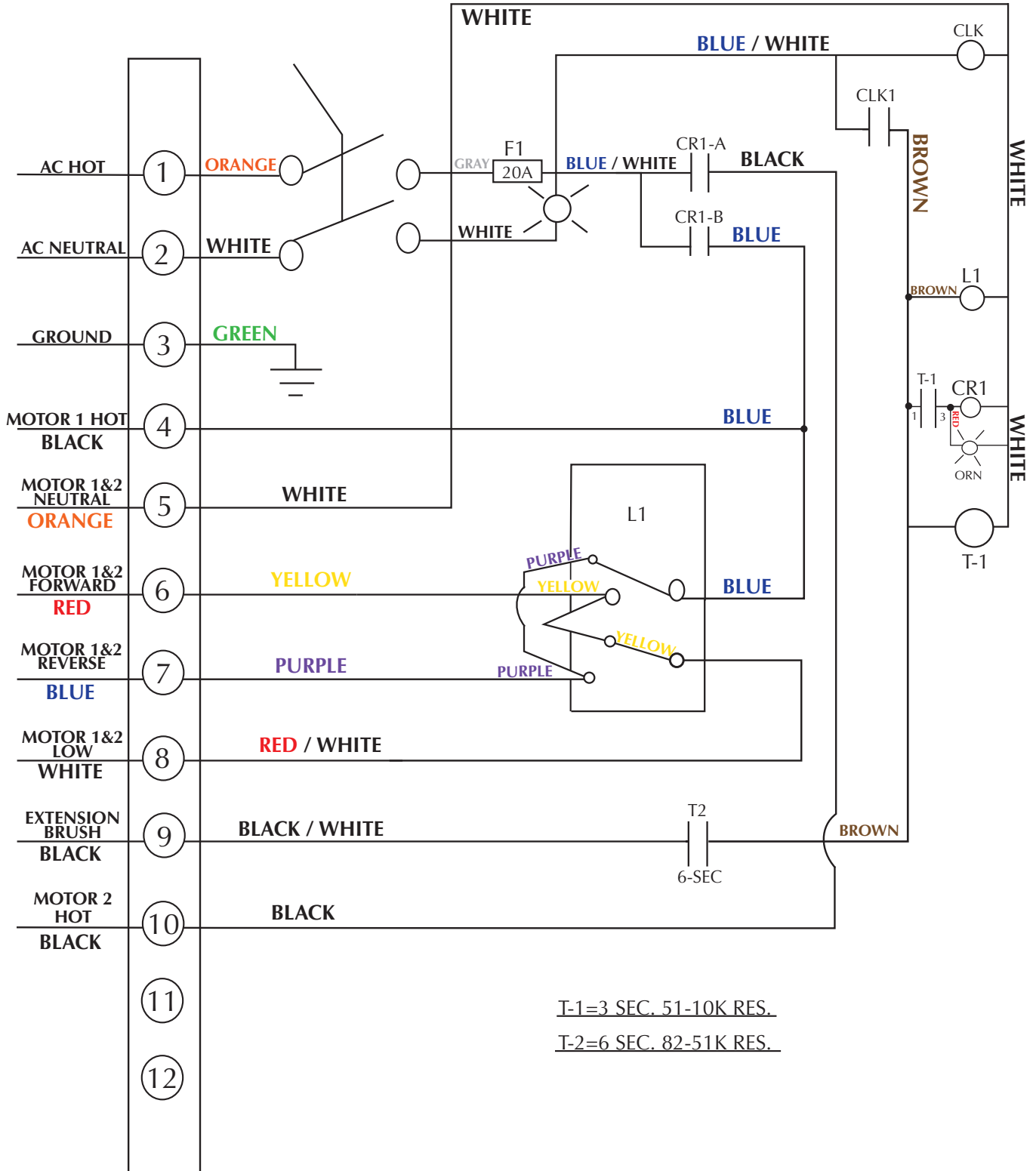

PROGRAMMING STEPS

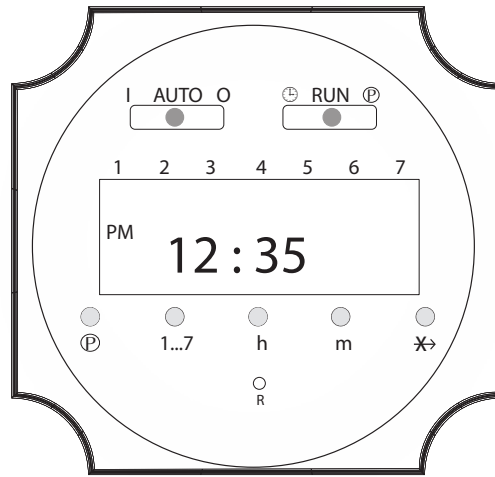

Clear All	To erase all settings press R
Set Time and Day	Slide set switch to ⊕. Press 1...7 buttons until arrow points to correct day (1=Mon. 2=Tues. 3=Wed. 4=Thurs. 5=Fri. 6=Sat. 7=Sun.) Press H then M buttons to set correct time. P.M. indicator shows noon til 11:59 P.M. Slide switch to RUN . Clock colon (:) will blink.
Set Switch on Cycle	Slide set switch to ⊖. 1 indicates the first switch cycle and a bulb indicates a switch on (circuit closes). Press 1...7 buttons until arrows point to selected day(s). For this cycle Press H then M buttons to show switch-on time noting P.M. indicator.
Set Switch Off Cycle	With set switch at ⊖ press ⊖ button, note switch cycle number changes to 2 and clock will blink, indicating switch-off (circuit opens). Press 1...7 buttons to match day(s). Set for switch cycle 1 . Press H then M buttons to select switch-off time. Repeat steps up to 8 on/off events. Slide set switch to RUN . Clock will blink.
Auto-Run Run Mode	Set time, day and desired switch cycles. Slide set switch to RUN and mode switch to AUTO . Switching begins with the next switch-on set time.
Override On	Slide mode switch to I . Switch remains on indefinitely (circuit closed).
Override Off	Slide remote switch to O . Switch remains off indefinitely (circuit open).
Skip Cycle	In automatic run mode, press ⊗→ button. The next calendar day is skipped.
Setting Error	If EEE appears, a setting error exists; the switch cycle number in error is shown. Slide set switch to ⊖. Press P button until cycle is shown. Review this and following setting to correct error. Slide set switch to RUN .
Clear Any Setting	Slide set switch to ⊖. Press P button to show switch cycle. To clear, press 1...7 buttons until no days are indicated. Repeat for following switch cycle. This on/off cycle is now inactive.

DL-60 MOTOR WIRING DIAGRAM

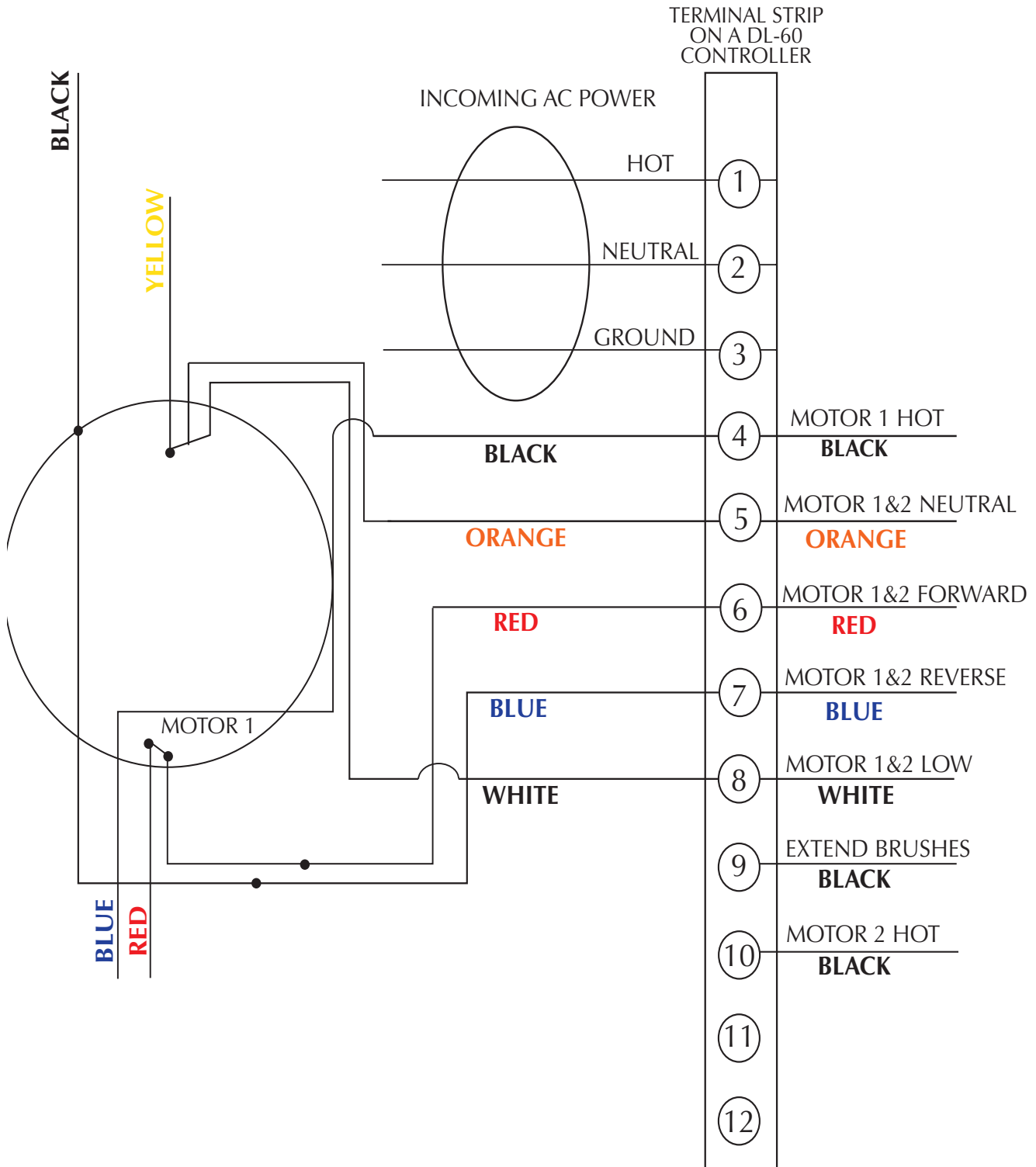

**DIGILUBE SYSTEMS 6"
STANDARD DL-60**

THIS DIAGRAM REPRESENTS ONE
OUT OF TWO BRUSH STACKS.

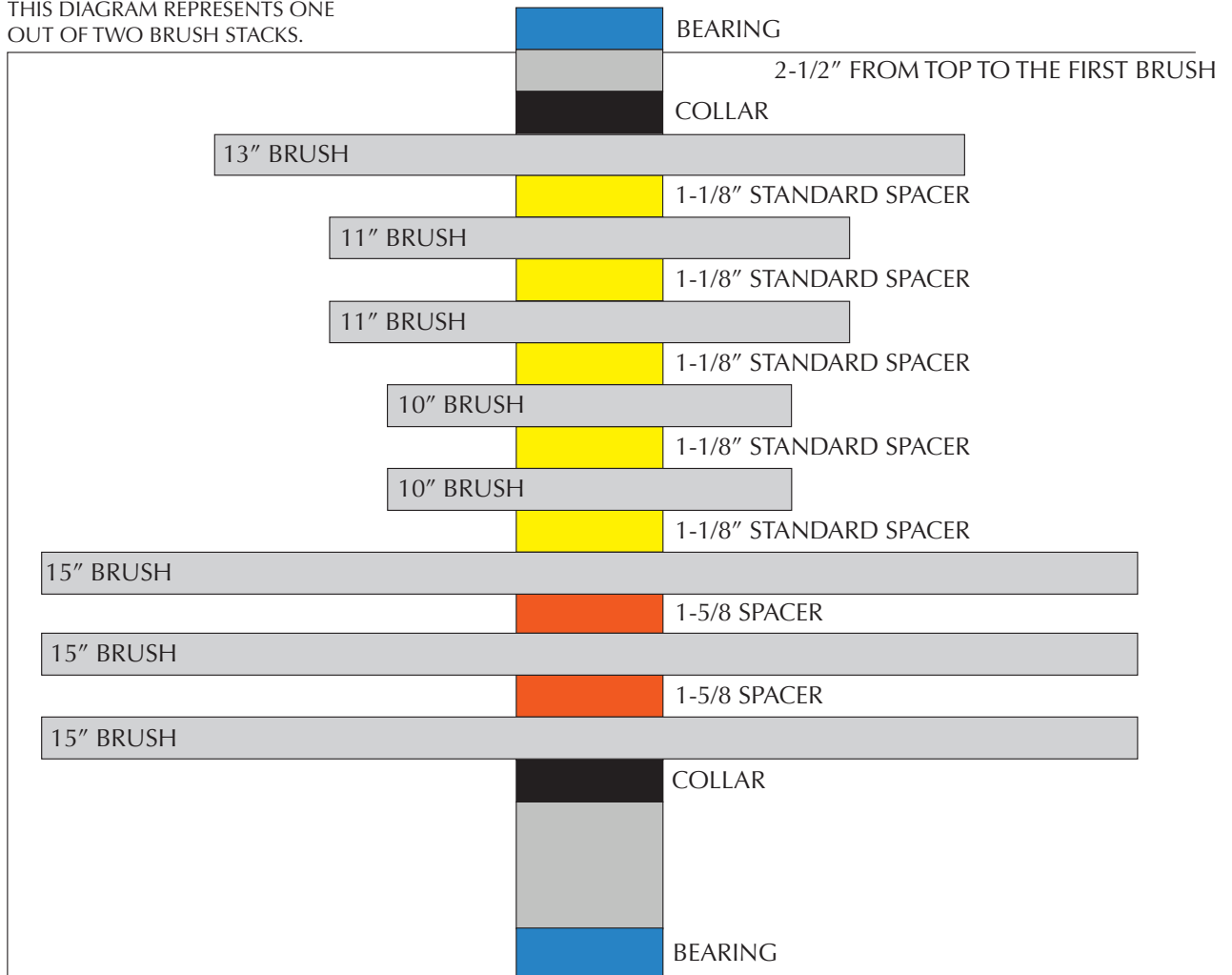

*ON 6" BRUSH, MOVE THE AIR CYLINDER IN 1" FOR 18" SHAFTS

CONTENTS:

- | | | |
|-----------------------|-----------------|------------------------------|
| (2) 1-1/4" SHAFTS 18" | (4) 11" BRUSHES | (10) 1-1/8" STANDARD SPACERS |
| 4 PIECES OF KEYSTOCK | (4) 10" BRUSHES | (4) 1-5/8" SPACERS |
| (2) 13" BRUSHES | (6) 15" BRUSHES | |