

Springboro, OH 45066  
937-748-2209  
sales@digilube.com  
www.digilube.com

# *digilube systems*

## **DL-60 6" MANUAL**

Parts List.....	2
Expanded View.....	3
Operation.....	4
Mounting.....	4
Air Supply.....	4
Electrical Needs.....	4
Start-up.....	5
Clock Programming.....	5
Wiring Diagram.....	6
Programming Steps.....	7
Motor Wiring Diagram.....	8
DL-60 Brush Stack.....	9

# DL-60 PARTS LIST

ITEM #	QTY	PART #	DESCRIPTION
1	2	E06397	Split Phase TEFC Motor
2	1	E06305	DL-60 Brush Controller
3	2	H14700	Upright Bracket
4	2	F11650	1/4" - 1/4" Prestolok Male Connector
5	2	F12559	Snubber, Air Valve
6	1	F13005	120 VAC Air Valve
7	1	F13005-1	Din Connector for Valve
8	1	G13513	Air Cylinder for DL-60
9	2	F11900	1/4" - 1/8" NPT Male Connector
10	1	G13512	Main Frame Assembly - <i>Items listed below</i>

## MAIN FRAME ASSEMBLY ITEMS

ITEM #	QTY	PART #	DESCRIPTION
11	----	----	Shaft Coupler (3/4 Bore)
12	----	----	Coupler Spider
13	----	----	Shaft Coupler (1-1/4 Bore)
14	----	----	Flange Mounted Ball Bearing
15	----	----	Brush Arm Plate
16	----	----	Bottom Brush Arm Plate
17	----	----	3/8-16 x 3/4 SHCS includes: 3/8" Lock Washer
18	----	----	Shaft Key
19	----	----	Brush Shaft - size varies
20	----	----	Gear Rack
21	----	----	Air Valve Mounting Bracket
22	----	----	Spur Gear Machined (1" Bore)
23	----	----	Gear Support
24	----	----	Gibb
25	----	----	Arm Bracket Frame

# DL-60 EXPANDED VIEW

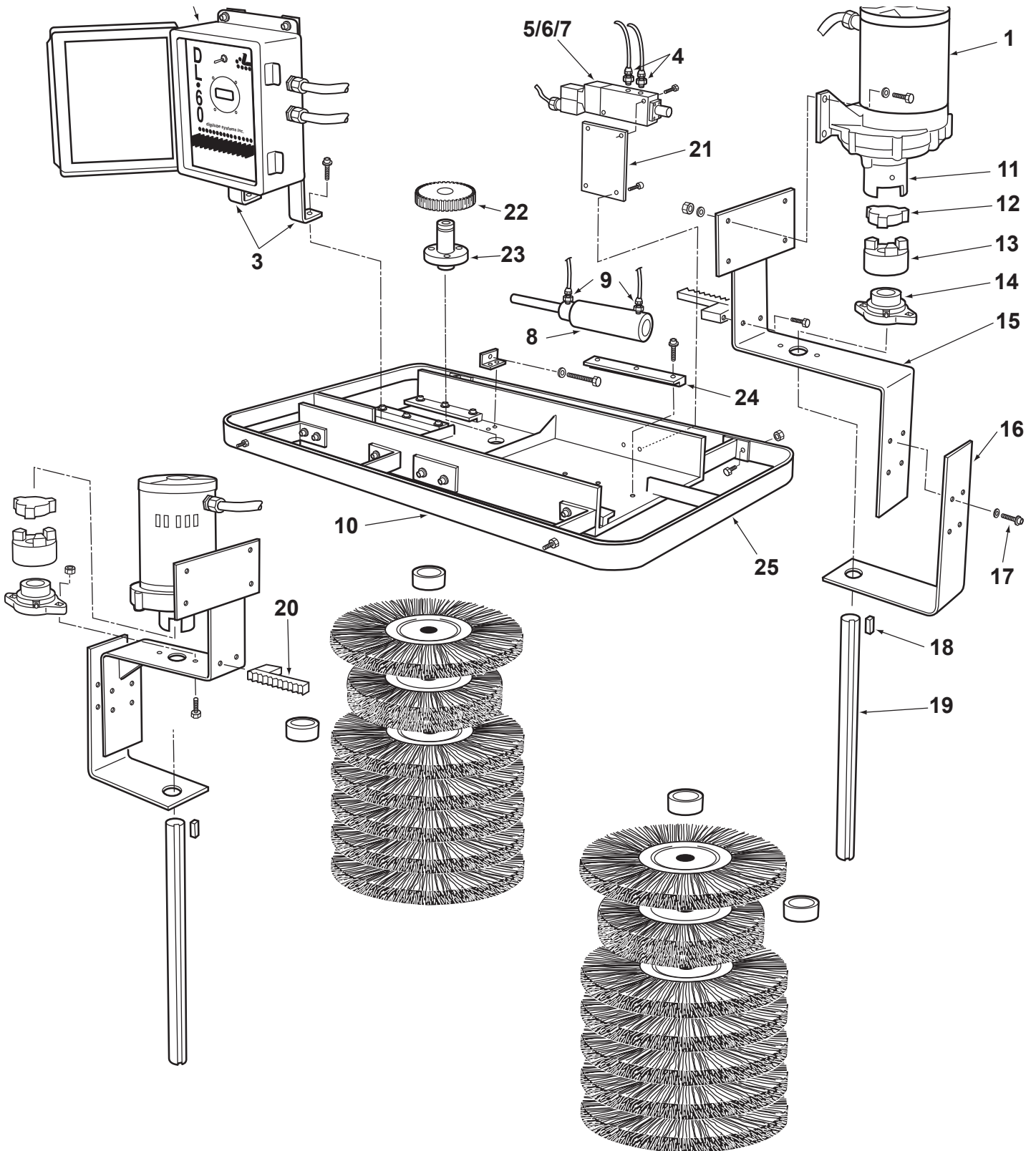

# THE DL-60 POWER CHAIN & TROLLEY CLEANING SYSTEM

The DL-60 is powered by twin direct drive gear motors to provide maximum brush torque without the use of chain, belts, sprockets or pulleys. This unit is designed to remove and prevent the buildup of paint, dirt, scale, and rust on the conveyor's chain and trolleys.

## OPERATION

The controller on the DL-60 allows the user to program the cleaning operation for either automatic or manual modes. In either mode the controller will automatically reverse the rotation on the brushes every time the unit is started. This feature helps prolong the life of the brushes and allows the brushes to attack the buildup from a different direction for more effective cleaning. While the programmable controller will allow up to 8 (on/off) complete cleaning cycles every day when set in the automatic mode, most conveyors will reach optimum conditions when cleaned once a week. As the cleaning cycle begins, the controller provides power to each motor. Once the motors are rotating, the air cylinder will engage and bring the arms in to begin the cleaning process as the brushes make light contact with the passing conveyor chain and trolleys. The amount of brush contact is determined by the adjustable stop located on top of the base plate. Upon completion of the cleaning cycle, the brushes retract and stop rotating. When in automatic mode, the system will shut down until the next cleaning cycle. In the manual mode, the DL-60 must be turned on or off by the power switch located inside the controller.

## MOUNTING

Before mounting the DL-60 into place, consideration should be given to the location of the unit and how the weight of the unit may affect the conveyor. The preferred locations for mounting is: (a) between the load and unload area or (b) before the washer. In some applications such as in an inverted unit, additional supports may be needed to support the DL-60. The DL-60 should be lifted into place with chains attached to the outer sides of the base plate. Once in place, the DL-60 should be centered on the rail and secured by welding the front and rear mounting tabs to the top of the rail. The dust curtain should be attached to the frame with the enclosed mounting hardware.

## AIR SUPPLY

A regulated and filtered plant air supply line is required for operation. The DL-60 requires a minimum of 40psi of compressed air for operation. The regulator and filter are to be supplied by the customer. A quick disconnect should be used to allow for easier service as needed.

## **ELECTRICAL NEEDS**

The DL-60 requires 115 VAC 25 amp service. The DL-60 is completely wired and the only connection needed to be made is the incoming power. A knockout hole located in the bottom of the controller is provided for the incoming power. Please refer to the wiring diagram for actual connections.

## **START-UP**

Before you first start up the DL-60, it is necessary to first adjust the brushes so that they are equally positioned against the chain and trolleys. To accomplish this:

- » You must first turn the plant air to the unit off and release the pressure from the cylinder by removing one of the 1/4" air lines from the solenoid valve.
- » Next remove the ring clamp on top of the ring gear.
- » Pull the gear straight up so the brush arms will move freely.
- » Adjust the stop set screw for maximum arm movement.
- » Adjust both arms so that they apply light pressure against the chain and trolleys.
- » At this point reset the ring gear and adjust the stop set screw to restrict the arms from moving in further, and reconnect the plant air line.

## **TO PROGRAM THE CLOCK OF THE DL-60 CONTROLLER**

You should first press the reset button located in the center of the clock. This will remove any presets from the controller and avoid inadvertent operation of the unit. You should then proceed to set the actual time and day of the week into the clock. Once this has been accomplished you can now program in up to 8 complete cleaning cycles per day, however most systems can be kept clean with a single cleaning once a week or less. For complete programming, see page 7.

# DL-60 WIRING DIAGRAM

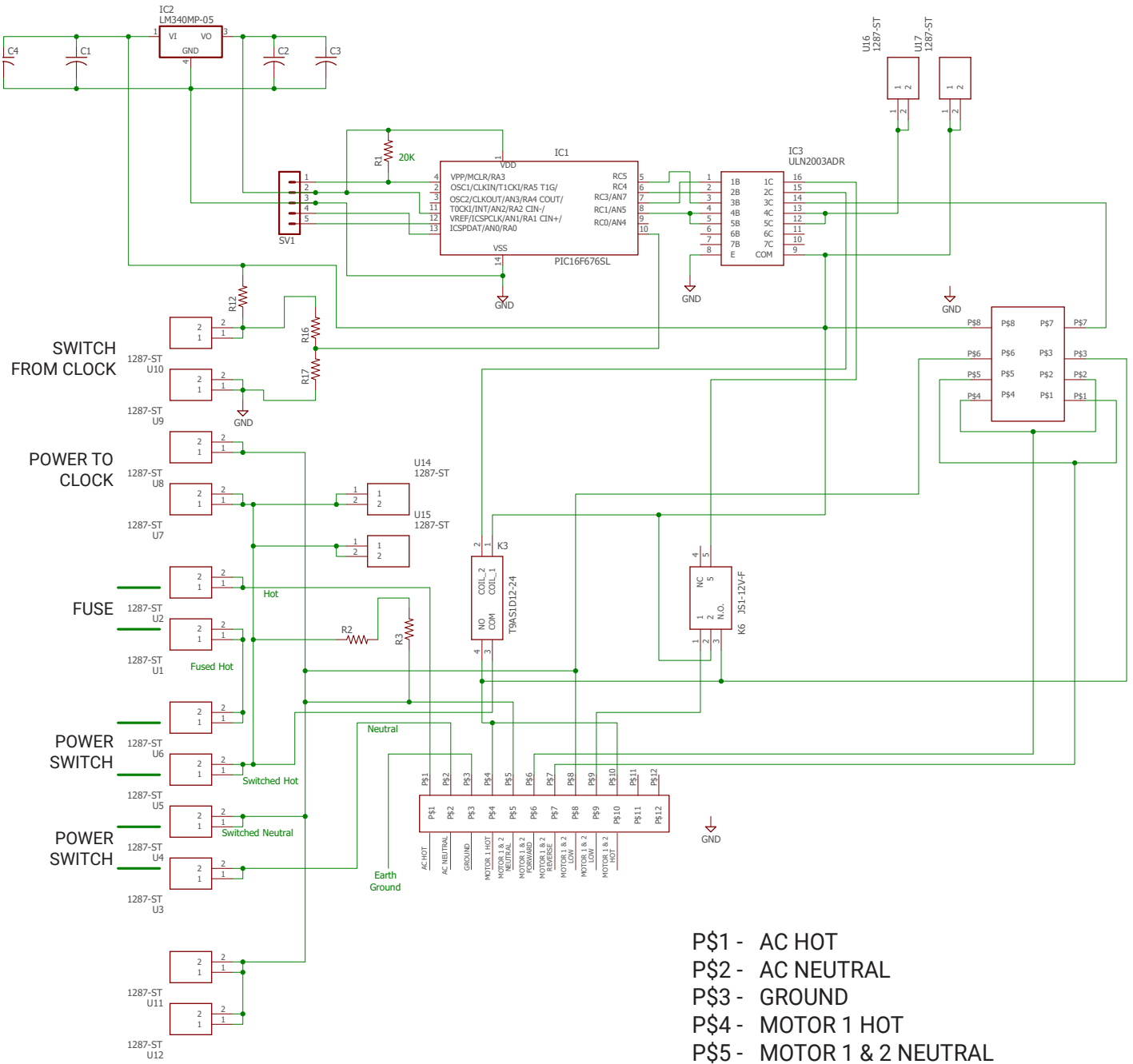

- P\$1 - AC HOT
- P\$2 - AC NEUTRAL
- P\$3 - GROUND
- P\$4 - MOTOR 1 HOT
- P\$5 - MOTOR 1 & 2 NEUTRAL
- P\$6 - MOTOR 1 & 2 FORWARD
- P\$7 - MOTOR 1 & 2 REVERSE
- P\$8 - MOTOR 1 & 2 LOW
- P\$9 - EXTENSION BRUSH
- P\$10 - MOTOR 1 & 2 HOT

# PROGRAMMING STEPS

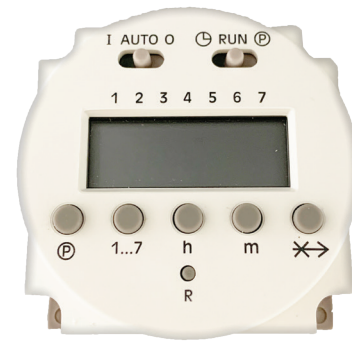

<b>CLEAR ALL</b>	To erase all settings press R
<b>SET TIME AND DAY</b>	<ul style="list-style-type: none"> <li>» Slide set switch to ⊕. Press 1...7 buttons until arrow points to correct day (1=Mon. 2=Tues. 3=Wed. 4=Thurs. 5=Fri. 6=Sat. 7=Sun.)</li> <li>» Press H then M buttons to set correct time. P.M. indicator shows noon til 11:59 P.M.</li> <li>» Slide switch to RUN. Clock colon (:) will blink.</li> </ul>
<b>SET SWITCH ON CYCLE</b>	<ul style="list-style-type: none"> <li>» Slide set switch to P.</li> <li>» 1 indicates the first switch cycle and a bulb indicates a switch on (circuit closes).</li> <li>» Press 1...7 buttons until arrows point to selected day(s).</li> <li>» For this cycle Press H then M buttons to show switch-on time noting P.M. indicator.</li> </ul>
<b>SET SWITCH OFF CYCLE</b>	<ul style="list-style-type: none"> <li>» With set switch at P, press P button, note switch cycle number changes to 2 and clock will blink, indicating switch-off (circuit opens).</li> <li>» Press 1...7 buttons to match day(s).</li> <li>» Set for switch cycle 1.</li> <li>» Press H then M buttons to select switch-off time.</li> <li>» Repeat steps up to 8 on/off events.</li> <li>» Slide set switch to RUN. Clock will blink.</li> </ul>
<b>AUTO-RUN RUN MODE</b>	<ul style="list-style-type: none"> <li>» Set time, day and desired switch cycles.</li> <li>» Slide set switch to RUN and mode switch to AUTO.</li> <li>» Switching begins with the next switch-on set time.</li> </ul>
<b>VERRIDE ON</b>	Slide mode switch to I. Switch remains on indefinitely (circuit closed).
<b>VERRIDE OFF</b>	Slide remote switch to O. Switch remains off indefinitely (circuit open).
<b>SKIP CYCLE</b>	In automatic run mode, press ↔ button. The next calendar day is skipped.
<b>SETTING ERROR</b>	<ul style="list-style-type: none"> <li>» If EEE appears, a setting error exists; the switch cycle number in error is shown.</li> <li>» Slide set switch to P. Press P button until cycle is shown.</li> <li>» Review this and following setting to correct error.</li> <li>» Slide set switch to RUN.</li> </ul>
<b>CLEAR ANY SETTING</b>	<ul style="list-style-type: none"> <li>» Slide set switch to P. Press P button to show switch cycle.</li> <li>» To clear, press 1...7 buttons until no days are indicated.</li> <li>» Repeat for following switch cycle. This on/off cycle is now inactive.</li> </ul>

# DL-60 MOTOR WIRING DIAGRAM

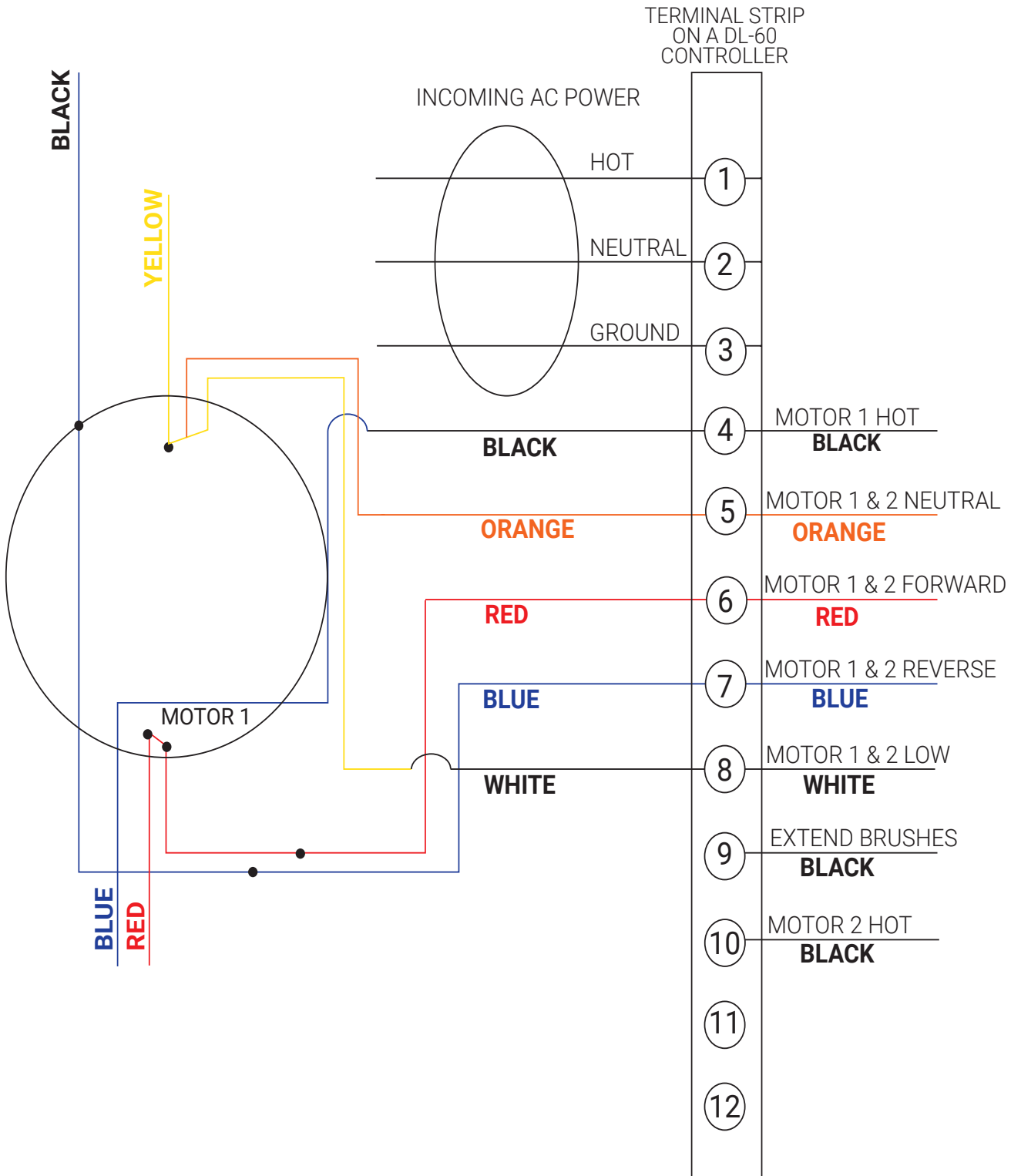



# DL-60 6" BRUSH STACK A02255-6

THIS DIAGRAM REPRESENTS ONE OF TWO BRUSH STACKS.

\*ON 6" BRUSH, MOVE THE AIR CYLINDER IN 1" FOR 18" SHAFTS

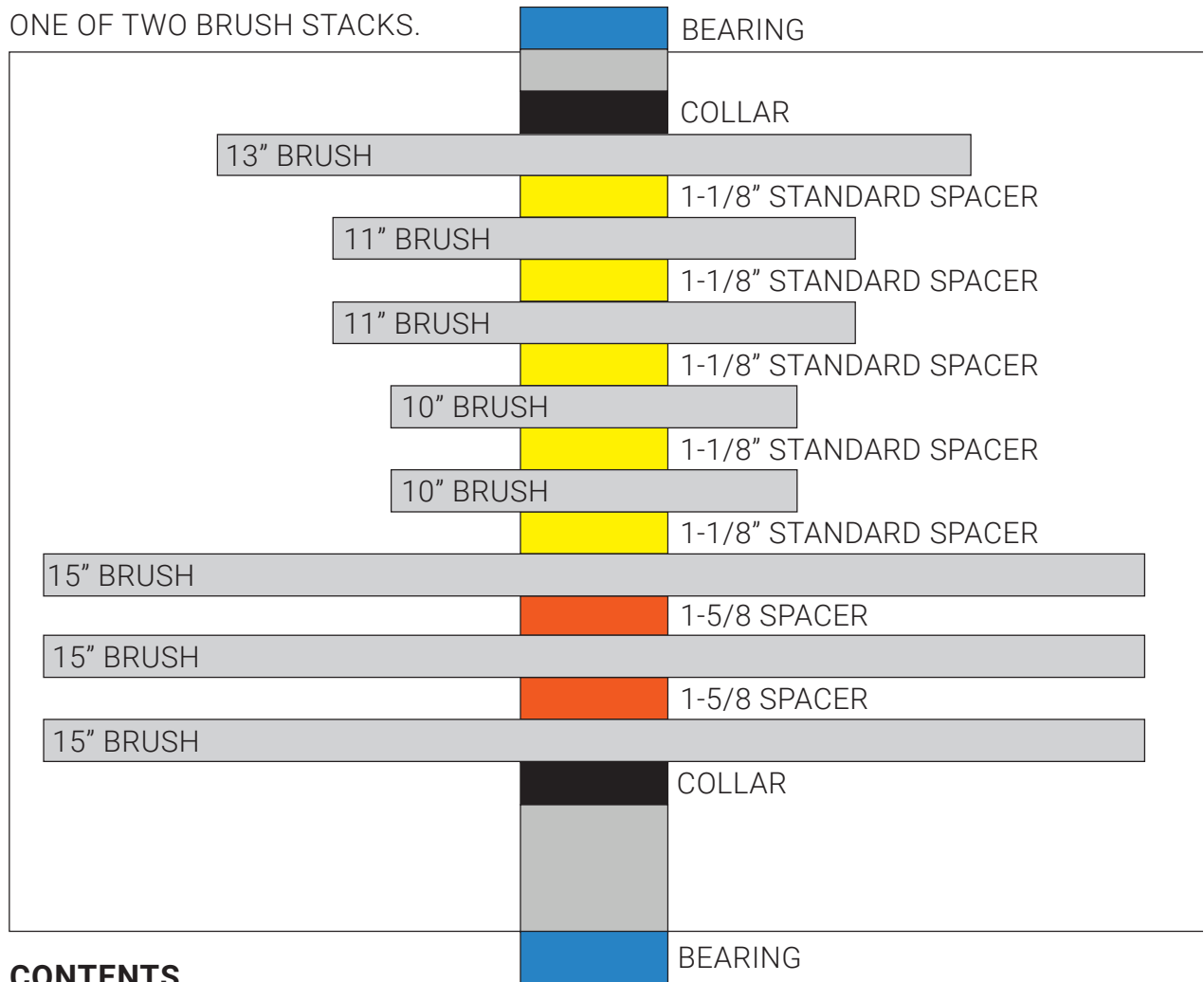

## **CONTENTS**

<b>PART #</b>	<b>QTY</b>	<b>DESCRIPTION</b>
G13450 *	4	10" CRIMPED BRUSHES
G13490 *	4	11" CRIMPED BRUSHES
G13503 *	2	13" CRIMPED BRUSHES
G13505 *	6	15" CRIMPED BRUSHES
G13750 *	16	1-1/8" NYLON SPACERS
G13746 *	4	1-5/8 NYLON SPACERS
G13526	2	18" BRUSH SHAFTS
H13971	4	5/16" KEY STOCK

**A02255-6RB**  
\* 6" Replacement Brush Set