



digilube systems

ENCLOSED POWER CHAIN & FREE CARRIER LUBRICATOR

FEATURES

- Microprocessor controlled
- Millisecond dispensing accuracy
- Field programmable security code
- Exclusive self-diagnostic feature available
- Large 2-line LCD screen
- 4 independent channels
- Tracks lube usage per cycle
- Displays approximate line speed
- 16 button programmable key pad
- Sturdy dispensing tubes resist vibration
- PC interface contacts (optional PLC contacts)
- Automatic fault shut-down
- All electronic
- 1 year warranty
- 3 year microprocessor warranty

DL-143PF

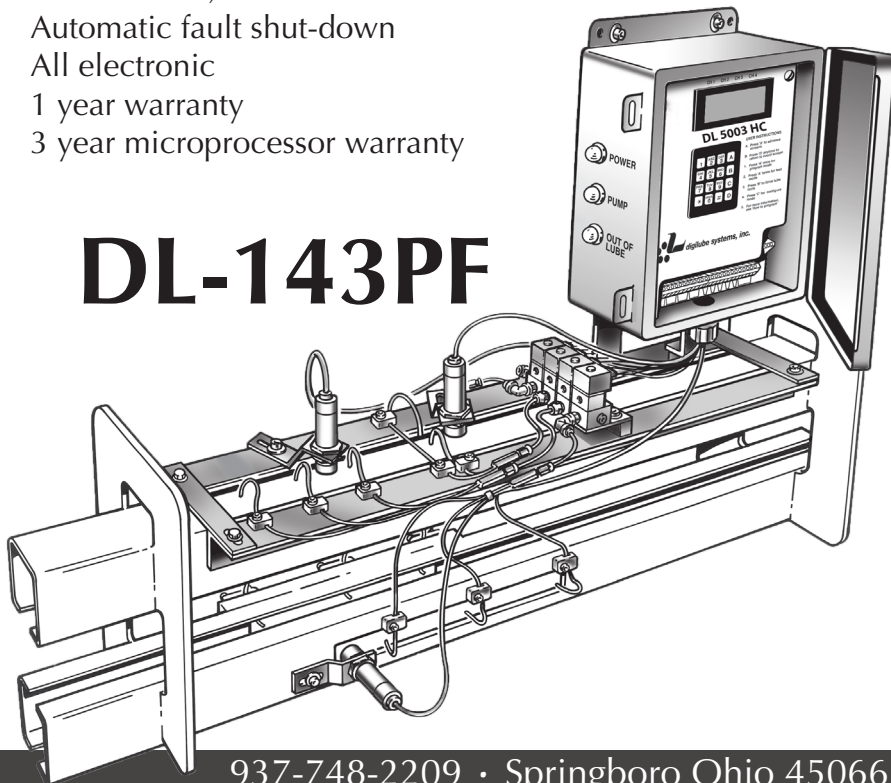

SPECIFICATIONS

POWER SOURCE	120VAC OR 24VDC
DIMENSIONS	28"L x 17"H x 6"W
LUBRICANT POINTS	» Power track vertical load wheel bearings » Horizontal guide roller bearings (P&F) » Connecting knuckle pivot points » 4 wheel attachments » Free trolley open load wheel bearings
OPTIONAL LUBE POINTS AVAILABLE	
AVAILABLE FOR STEEL OR PLASTIC TREAD CHAINS	

*Equipment Compatible With
All Conveyor Manufacturers
Including: Richard Wilcox,
Unibilt, Gregory Adams & Allied.*