



DL-20

NON-POWERED CONVEYOR CLEANER

The DL-20 is an Economical Enclosed Track, Non-Powered Conveyor Brush Designed to Clean the Chain of Unibilt, Rapidflex, Zigzag, High Performance E-Chain, Allied Conveyors and many more. The Three Arm Design with 6' Diameter Crimped Steel Brushes, Cleans the Top and Both Sides of the Chain. Adjustable Tension Bolts allow the Brushes to Drag as the Chain Travels Through the Brushes, Scraping Debris off the Chain. Optional Debris Trays Catch Debris.

FEATURES

- Removes Dirt, Lubricant and Paint Build-Up
- Reduces Conveyor Friction
- Minimizes Product Contamination
- Eliminates Manual Cleaning Expenses
- Portable and Economical
- Crimped Steel Bristles for Long-Life and High Wear Resistance
- Brushes Adjustable at 2 Locations for Turning Tensions and Brush-To Conveyor Tension
- Cleans Top and Sides of Enclosed Track Conveyor Chain

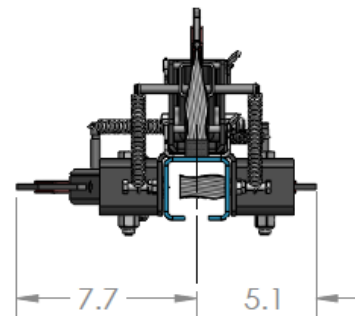
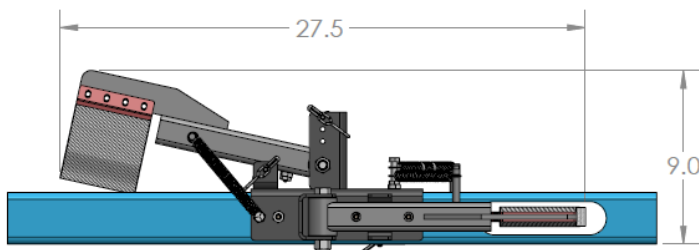
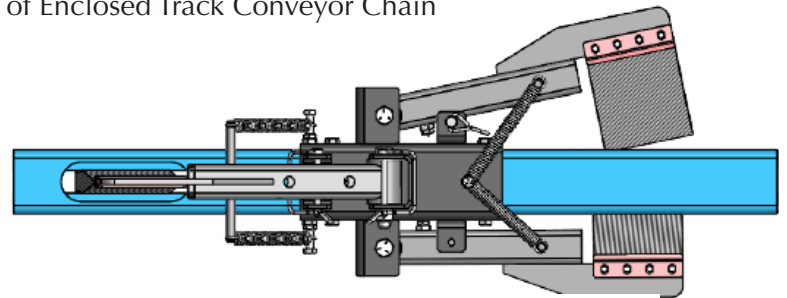
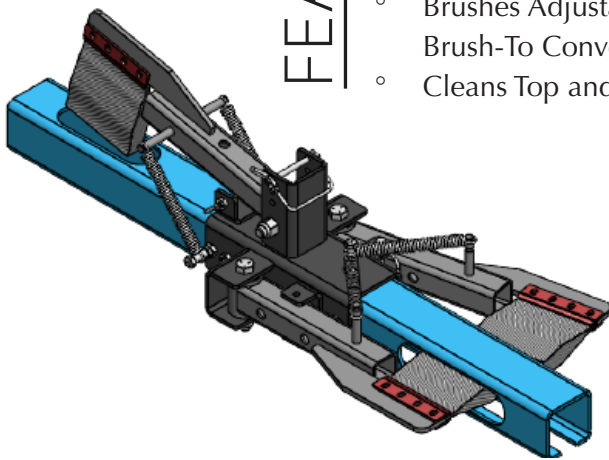

ENCLOSED TRACK CUTOUT

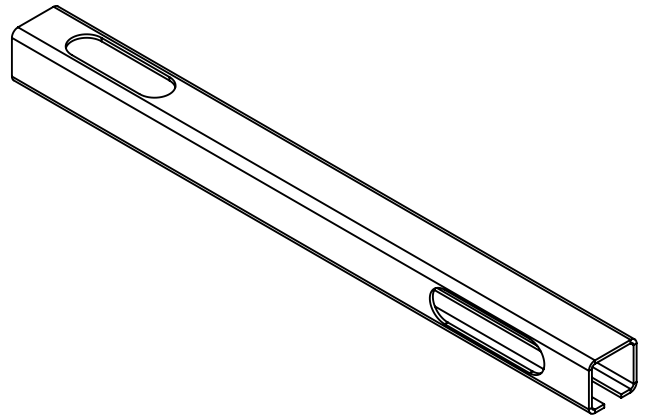

RICHARDS WILCOX TRACK

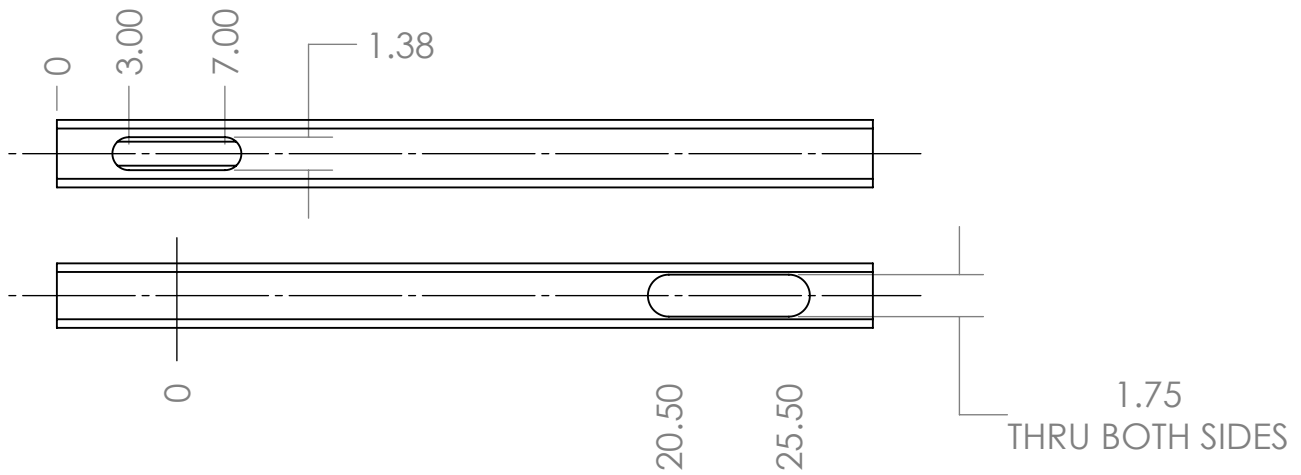

UNIBILT TRACK

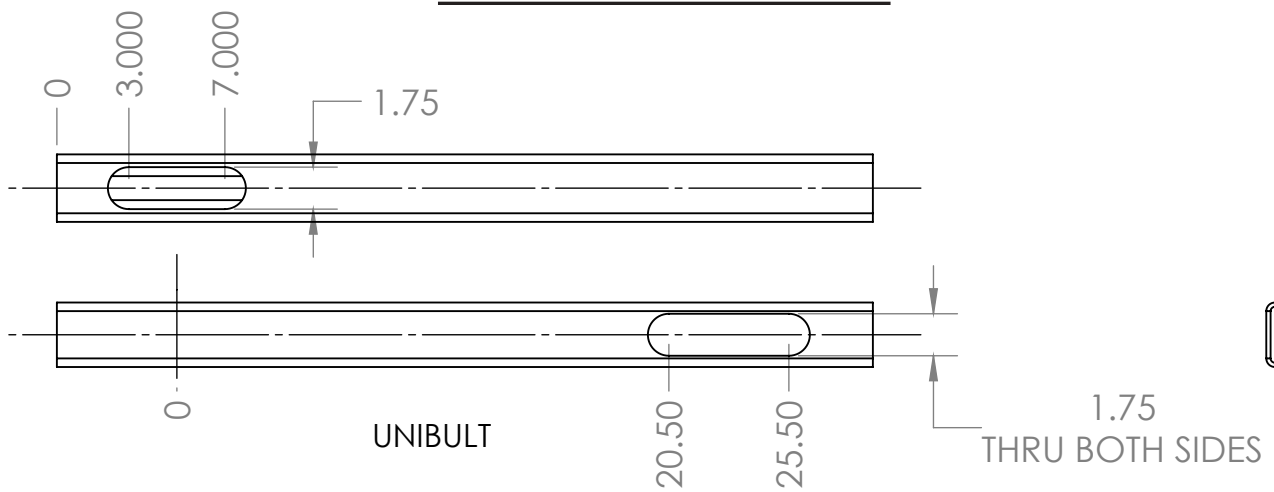

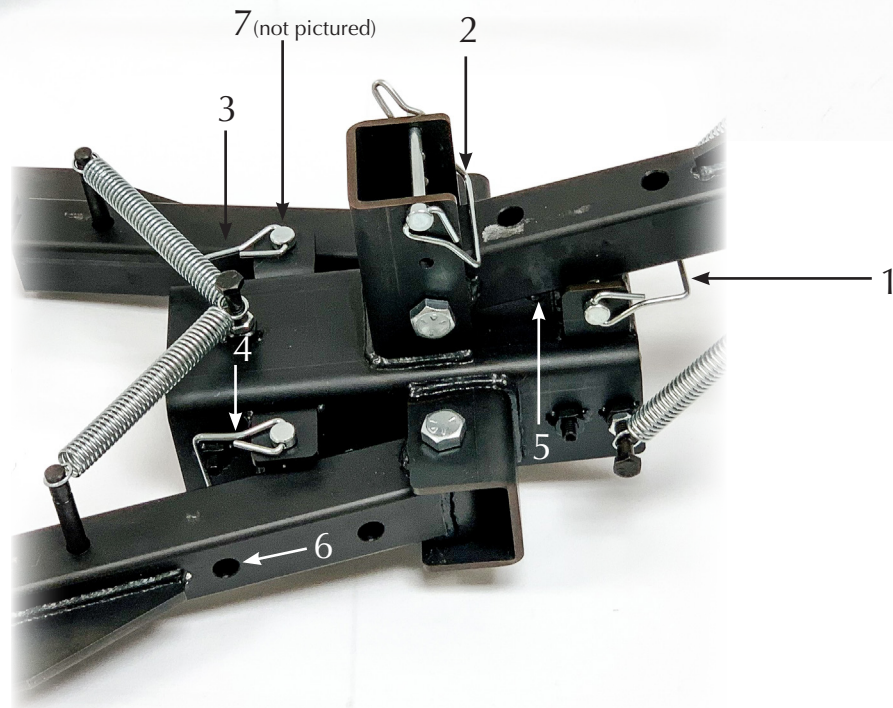
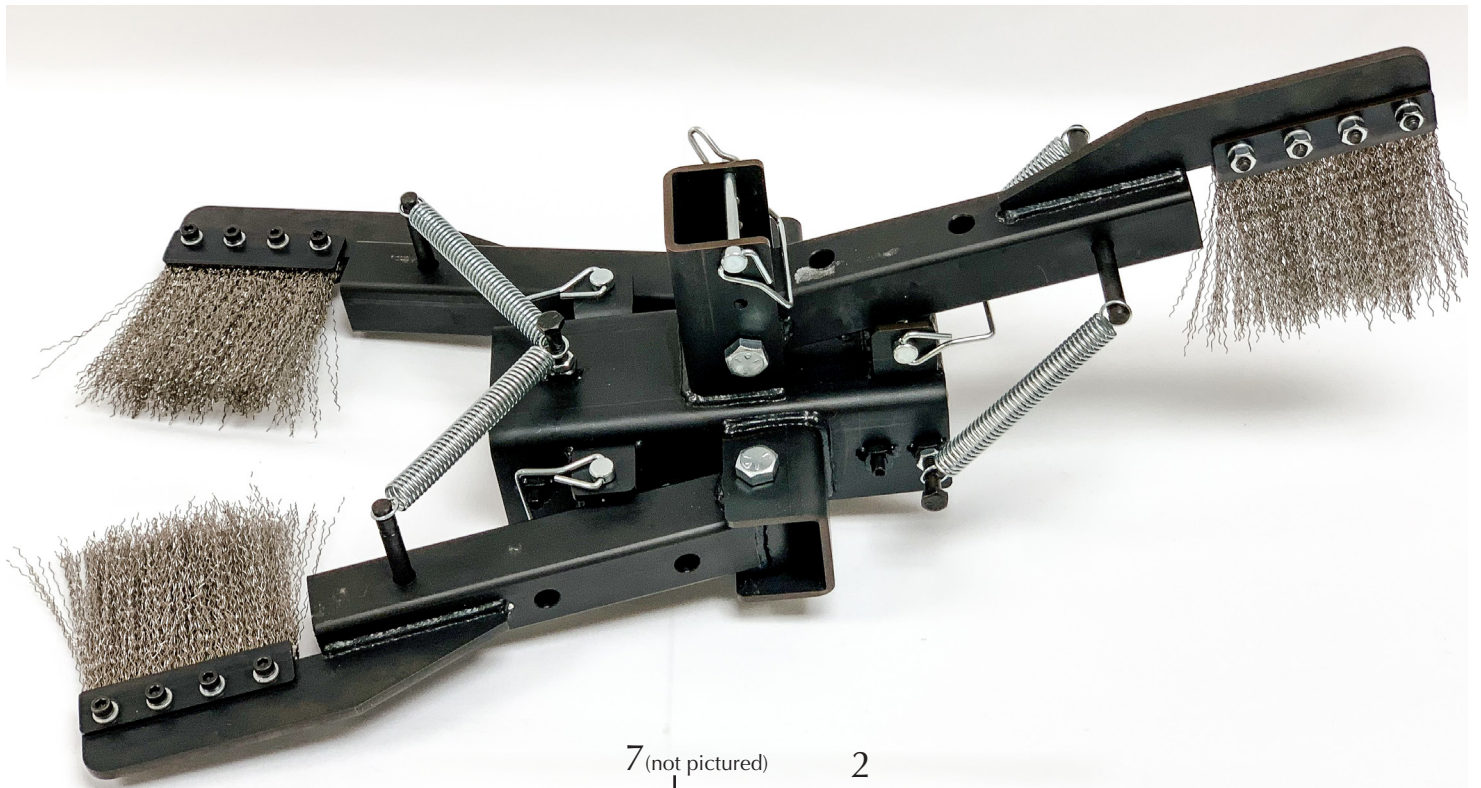

ITEM #	DESCRIPTION	
1-4	Locking Pins with Retainers	Pins should be Installed when the Brush Unit is in Non-Operational Mode & Removed when the Brush Unit is in Operation.
5 6 & 7 (Not Pictured)	5/16-18 x 1" Ball Set Screw and 5/16-18 Jam Nut	Tensioners for the Brushes: Adjust Set Screw for Desired Brush Tension for Cleaning