

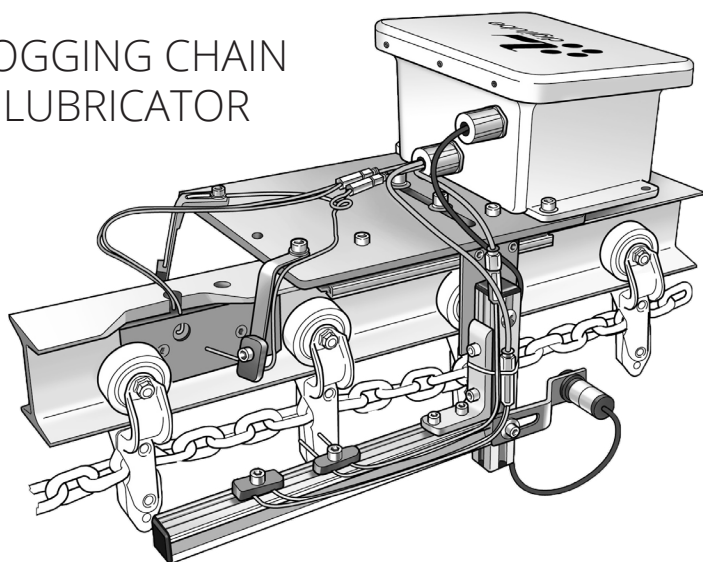

POULTRY PROCESSING APPLICATIONS

LOGGING CHAIN LUBRICATOR



FEATURES

- DI-5003 Controller With Menu Driven Programming; Continuous Display Readout
- Microprocessor Controlled
- Lubricator Status Indicator Lights
- Processor Incorporates Memory Backup and Automatic Restart
- Sturdy Dispensing Tubes Resist Vibration
- Optional PLC Interface Contacts
- Pre-Mounted on 24" Section of Stainless, Galvanized and Round Track Applications
- Designed to Withstand Wet Environments
- Stainless Steel Aluminum Design
- 3 Year Warranty

SERVICE

- Factory Backed Warranty
- Factory Trained Field Service Available
- Service Contracts Available
- Emergency Service Available
- Training and Preventive Maintenance Seminars Available

These Systems are Designed Specifically for use with Thin Film Type Lubricants, including Ultra-Film FG

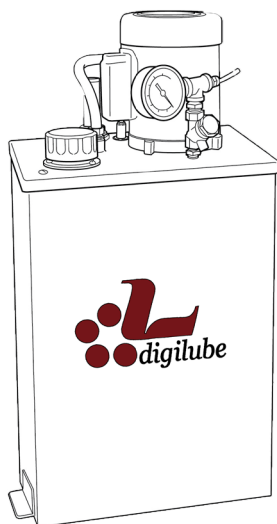

Digilube Offers Three Sizes of Lubricant Tanks: 6, 12 & 65 Gallon

Each Tank is Designed to Provide Lubricant to Both Single and Multiple Conveyors

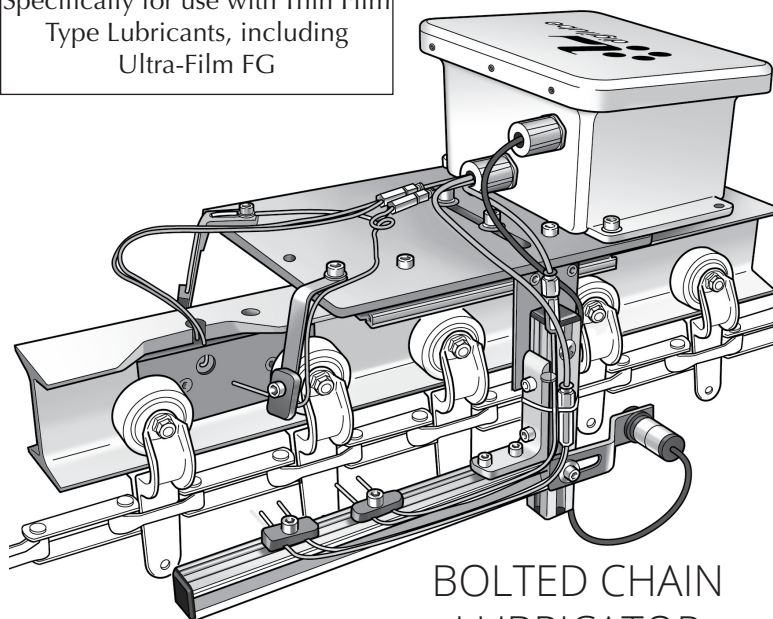

BOLTED CHAIN LUBRICATOR

www.digilube.com

216 East Mill St. Springboro, OH 45066 • (Office) 937-748-2209 • sales@digilube.com